

M16C/62

Using the M16C/62 Analog to Digital Converter in Single Sweep Mode

1.0 Abstract

The following article outlines the steps necessary to set up, perform, and read a single sweep conversion using the onboard analog to digital converter (ADC) of the M16C. The ADC is useful in measuring output voltages of sensors such as accelerometers or other analog instrumentation and converting them to digital values.

2.0 Introduction

The M16C line of devices features an onboard analog to digital converter (ADC). The ADC consists of one 10-bit successive approximation circuit with a capacitive coupled amplifier. There are eight analog input pins, selectable conversion clock speeds, sample and hold function, and several conversion modes. Figure 1 is an overview of the internal circuitry for the ADC block.

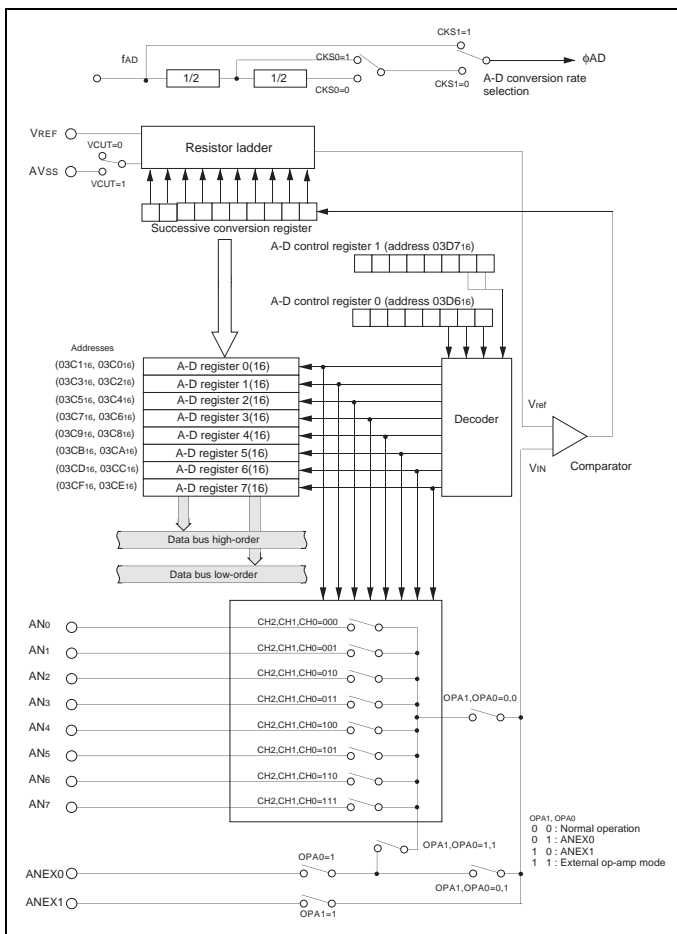

Figure 1 Internal Circuitry for ADC Block—Overview

3.0 Single Sweep Mode Description

In single sweep mode, multiple pins of the ADC can be selected as the input source. Once triggered, a single conversion takes place on each of the selected pins and the result is stored in the ADC result registers corresponding to the selected channels. An interrupt is generated signifying the completion of the conversions. Figure 2 and Figure 3 are overviews of the registers that will be used in this example. These registers are detailed in the included sample code.

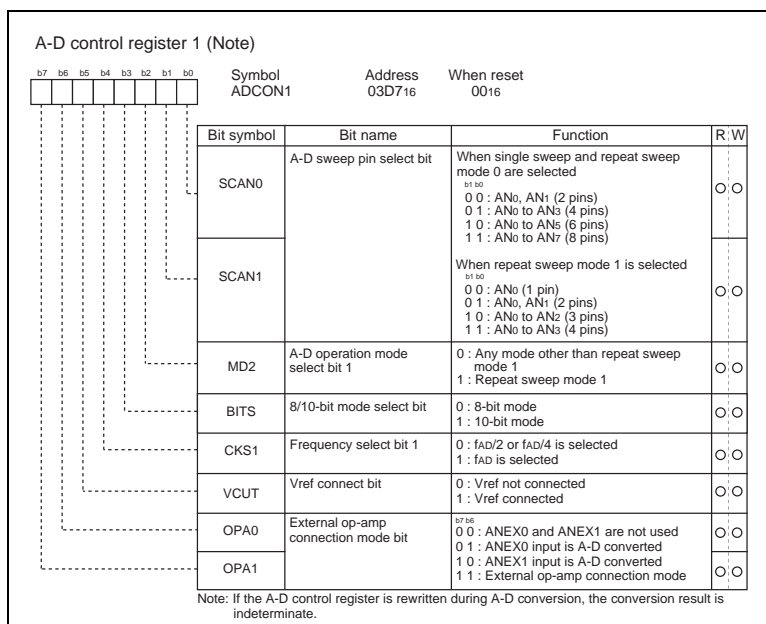
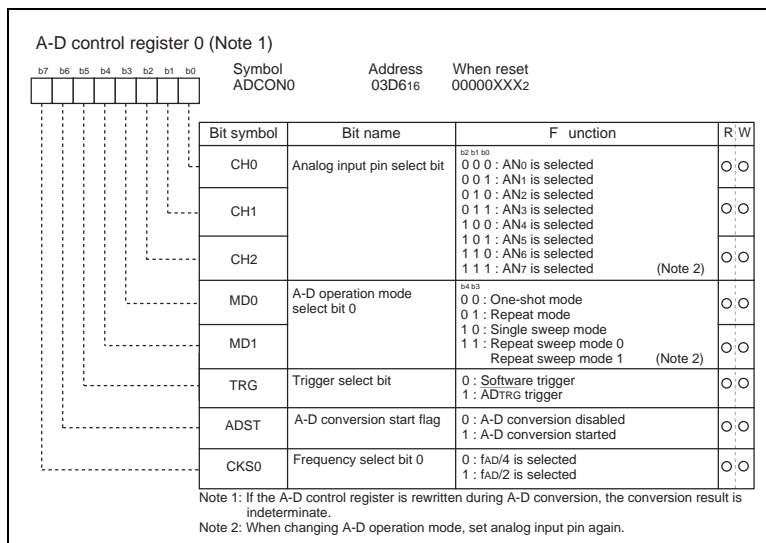

Figure 2 A-D Converter Related Registers

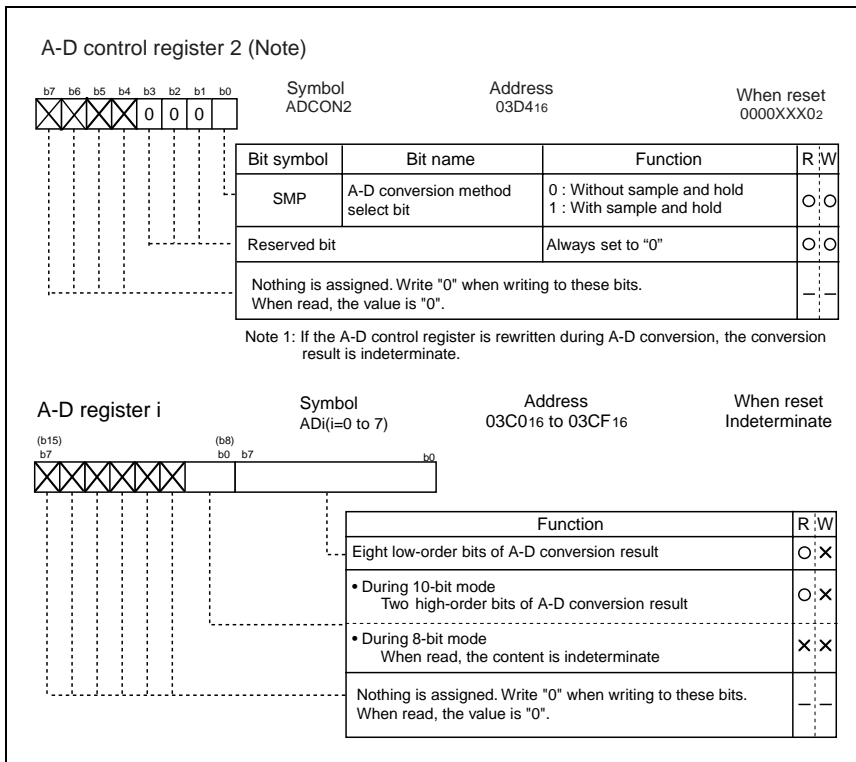

Figure 3 A-D Converter Related Register

4.0 Example Program

This example program demonstrates how to perform a conversion using the ADC in the following environment:

Environment Setup

- Single sweep conversion
- 10-bit mode
- Analog inputs 0–3 used
- Sample and hold enabled
- Vref connected
- Conversion clock used will be $f_{AD}/2$
- Software conversion start

ADC Software Setup

- Set the ADCON0 register for single sweep mode 0 operation, $f_{AD}/2$ (0x90)
- Set the ADCON1 register for 10-bit mode, f_{AD} divided, AN0-3 sweep, and connect Vref (0x29)
- Set the ADCON2 register for sample and hold (0x01)
- Enable the A/D converter by setting the ADST bit to 1
- Read current A/D channel values in the variables 'TempStore(x)' in the AD Interrupt Service Routine

5.0 Reference

Renesas Technology Corporation Semiconductor Home Page

<http://www.renesas.com>

E-mail Support

support_apl@renesas.com

Data Sheets

- M16C/62 datasheets, 62aeds.pdf

User's Manual

- NC30 Ver. 4.0 User's Manual, NC30UE.pdf
- M16C/60 and M16C/20 C Language Programming Manual, 6020EC.pdf
- M16C/62 User's Manual, 62eum.pdf
- Application Note: Writing Interrupt Handlers in C for the M16C

6.0 Software Code

The sample software provided was written using the NC30 compiler. The program performs one set of conversions on reset. This code could be simply modified to use a timer for the trigger of the ADC to provide multiple conversions at specific intervals.

```

/*****
 *
 *   DESCRIPTION: single_sweep.c
 *
 *   AUTHOR: Renesas Technology Corporation (June 2003)
 *
 *
 *   PURPOSE: Outlines how to use the M16C/62 ADC in single sweep
 *            mode. On reset, program stores the results of the
 *            conversions in variables that can be examined using
 *            KD30 and the MSV1632-62 Starter Kit
 *
 *****/
#include "sfr62.h"

unsigned int TempStore0 = 0x0000;    // Location where AN0 result is stored
unsigned int TempStore1 = 0x0000;    // Location where AN1 result is stored
unsigned int TempStore2 = 0x0000;    // Location where AN2 result is stored
unsigned int TempStore3 = 0x0000;    // Location where AN3 result is stored

#pragma INTERRUPT ADCInt             /* compiler directive indicating
                                     the proper return method for this function
                                     (REIT vs. RTS) */

```

```

void ADCInt(void);

/*
** main
*
* PARAMETERS: None
*
* DESCRIPTION: Main function. Where program execution starts. Sets
*               up the ADC then waits for interrupt to occur.
*
* RETURNS: Nothing
*
*/

void main (void){

    adcon0 = 0x90; /*10010000  single sweep mode, software trigger, fAD/2
                  |||||_____analog input select bit 0
                  |||||_____analog input select bit 1
                  |||||_____analog input select bit 2
                  |||||_____A/D operation mode select bit 0
                  |||||_____A/D operation mode select bit 1
                  |||_____trigger select bit
                  ||_____A/D conversion start flag
                  |_____frequency select bit */

    adcon1 = 0x29; /* 00101001; /* 10 bit mode, fAD divided, Vref connected,
ANO-3
                  |||||_____A/D sweep pin select bit 0
                  |||||_____A/D sweep pin select bit 1
                  |||||_____A/D operation mode select bit 1
                  |||||_____8/10 bit mode select bit
                  |||||_____frequency select bit 1
                  |||_____Vref connect bit
                  ||_____external op-amp connection bit 0
                  |_____external op-amp connection bit 1 */

    adcon2 = 0x01; /* 00000001; Sample and hold enabled
                  |||||_____sample and hold select bit
                  |||||_____reserved
                  |||||_____reserved
                  |||||_____reserved
                  |||||_____reserved
                  |||_____reserved
                  ||_____reserved
                  |_____reserved */

```

```

    adic = 0x01; /*00000001 Set Priority Level to Enable the ADC interrupt
                | | | | | | | | _____ interrupt priority select bit 0
                | | | | | | | | _____ interrupt priority select bit 1
                | | | | | | | | _____ interrupt priority select bit 2
                | | | | | | | | _____ interrupt request bit
                | | | | | | | | _____ reserved
                | | | | | | | | _____ reserved
                | | | | | | | | _____ reserved
                | | | | | | | | _____ reserved */

    _asm ("    fset i") ;    // globally enable interrupts

    adst = 1;                // Start a conversion here

    while (1){}             // Program waits here forever
}

/*
** ADCInt
*
* PARAMETERS: None
*
* DESCRIPTION: Interrupt routine of the ADC. Here the converted value is
*              loaded into a variable and masked off to show the result.
*
* RETURNS: Nothing
*
*/

void ADCInt(void) {

    TempStore0= ad0 & 0x03ff; // Mask off the upper 6 bits of the
                               // variable leaving only the result
                               // in the variable itself

    TempStore1= ad1 & 0x03ff; // Mask off the upper 6 bits of the
                               // variable leaving only the result
                               // in the variable itself

    TempStore2= ad2 & 0x03ff; // Mask off the upper 6 bits of the
                               // variable leaving only the result
                               // in the variable itself

    TempStore3= ad3 & 0x03ff; // Mask off the upper 6 bits of the
                               // variable leaving only the result
                               // in the variable itself

}

```

In order for this program to run properly, the ADC interrupt vector needs to point to the function. The interrupt vector table is near the end of the startup file "sect30.inc". Insert the function label "_ADCInt" into the interrupt vector table at vector 14 as shown below.

```

:
:
:

;-----
; variable vector section
;-----

.section      vector          ; variable vector table
.org      VECTOR_ADR

.lword dummy_int             ; BRK (vector 0)
.org      (VECTOR_ADR+16)

.lword dummy_int             ; int3(for user) (vector 4)
.lword dummy_int             ; timerB5(for user) (vector 5)
.lword dummy_int             ; timerB4(for user) (vector 6)
.lword dummy_int             ; timerB3(for user) (vector 7)
.lword dummy_int             ; si/o4 /int5(for user) (vector 8)
.lword dummy_int             ; si/o3 /int4(for user) (vector 9)
.lword dummy_int             ; Bus collision detection(for user) (v10)
.lword dummy_int             ; DMA0 (for user) (vector 11)
.lword dummy_int             ; DMA1 (for user) (vector 12)
.lword dummy_int             ; Key input interrupt(for user) (vect 14)
.glob      _ADCInt
.lword _ADCInt                ; A-D(for user) (vector 14)
.lword dummy_int             ; uart2 transmit(for user) (vector 15)
.lword dummy_int             ; uart2 receive(for user) (vector 16)
.lword dummy_int             ; uart0 transmit(for user) (vector 17)

:
:
:

```

Keep safety first in your circuit designs!

- Renesas Technology Corporation puts the maximum effort into making semiconductor products better and more reliable, but there is always the possibility that trouble may occur with them. Trouble with semiconductors may lead to personal injury, fire or property damage. Remember to give due consideration to safety when making your circuit designs, with appropriate measures such as (i) placement of substitutive, auxiliary circuits, (ii) use of nonflammable material or (iii) prevention against any malfunction or mishap.

Notes regarding these materials

- These materials are intended as a reference to assist our customers in the selection of the Renesas Technology Corporation product best suited to the customer's application; they do not convey any license under any intellectual property rights, or any other rights, belonging to Renesas Technology Corporation or a third party.
- Renesas Technology Corporation assumes no responsibility for any damage, or infringement of any third-party's rights, originating in the use of any product data, diagrams, charts, programs, algorithms, or circuit application examples contained in these materials.
- All information contained in these materials, including product data, diagrams, charts, programs and algorithms represents information on products at the time of publication of these materials, and are subject to change by Renesas Technology Corporation without notice due to product improvements or other reasons. It is therefore recommended that customers contact Renesas Technology Corporation or an authorized Renesas Technology Corporation product distributor for the latest product information before purchasing a product listed herein.
The information described here may contain technical inaccuracies or typographical errors.
Renesas Technology Corporation assumes no responsibility for any damage, liability, or other loss arising from these inaccuracies or errors.
Please also pay attention to information published by Renesas Technology Corporation by various means, including the Renesas Technology Corporation Semiconductor home page (<http://www.renesas.com>).
- When using any or all of the information contained in these materials, including product data, diagrams, charts, programs, and algorithms, please be sure to evaluate all information as a total system before making a final decision on the applicability of the information and products. Renesas Technology Corporation assumes no responsibility for any damage, liability or other loss resulting from the information contained herein.
- Renesas Technology Corporation semiconductors are not designed or manufactured for use in a device or system that is used under circumstances in which human life is potentially at stake. Please contact Renesas Technology Corporation or an authorized Renesas Technology Corporation product distributor when considering the use of a product contained herein for any specific purposes, such as apparatus or systems for transportation, vehicular, medical, aerospace, nuclear, or undersea repeater use.
- The prior written approval of Renesas Technology Corporation is necessary to reprint or reproduce in whole or in part these materials.
- If these products or technologies are subject to the Japanese export control restrictions, they must be exported under a license from the Japanese government and cannot be imported into a country other than the approved destination.
Any diversion or reexport contrary to the export control laws and regulations of Japan and/or the country of destination is prohibited.
- Please contact Renesas Technology Corporation for further details on these materials or the products contained therein.